

Comply and compatible with 19 inch international standard, metric system & ETSI standard. Welded structure, stable, static loading capacity 60 kg.



Product Description

Product Type	Single Door Wallmount Rack
Product ID	WR5015S
Size	15U
Weight	± 26 kg
Dimension (DxWxH)	500 x 600 x 780 mm
Complete Set with	<ul style="list-style-type: none"> • Glass Front Door and 2 Side Door with lock • 1 Unit Horizontal PDU 6 outlet with switch • 1 Unit Single Fan 220VAC • 1 pc Top Brush Panel • 4 pcs Dynabolt 88mm • 20 set M06 (Cagenuts & Screws)



Product Drawing

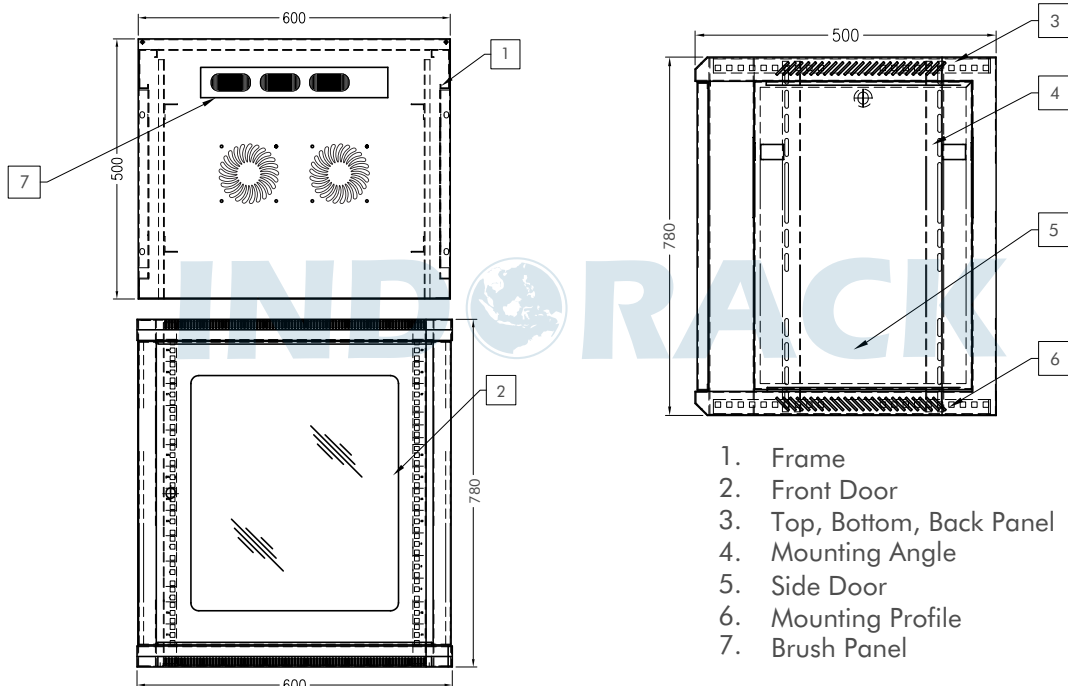

1. Frame
2. Front Door
3. Top, Bottom, Back Panel
4. Mounting Angle
5. Side Door
6. Mounting Profile
7. Brush Panel



Quick and easy wall mounted 19 inch standard installation inside. Open angle for front door is over 180 degrees. Removable lockable side door, cable entry from top and bottom.



Product Drawing

